

The series SMTIRMOD09 infrared sensor modules are especially designed for OEM applications where infrared radiation temperatures have to be measured. The various modules are based on our SMTIR99XX series of infrared sensors. The different modules have different fields of applications and therefore different fields of view. All the devices have an I<sup>2</sup>C output for standard interfacing to microcontrollers.

**FEATURES**

- Wide power supply voltage range
- Low current consumption < 2 mA
- Up to 0.5% accuracy
- Three types for selecting temperature range and field of view

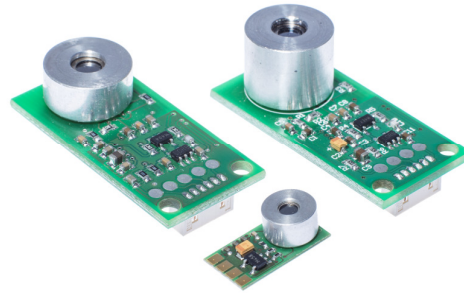

**APPLICATIONS**

- Contactless temperature measurement
- Climate control
- Industrial process control
- Household applications

**Product description**

The SMTIRMOD09 series of infrared modules are especially designed for applications where high accuracy is needed. For doing experiments with infrared sensing we point on our SMTIRIN06 infrared module where the applicant has software to change all kind of parameters. For easy and sophisticated interfacing the modules are equipped with an I<sup>2</sup>C interface bus. For different applications the field of view can be chosen from 14 till over 120 °. Especially for battery and 'hand-held' applications a very small low power consuming version is designed. For convenient interfacing the modules to PC or laptop I<sup>2</sup>C to USB interfaces are available.

**Characteristics**

All the electric parameters are given at an ambient temperature of 25 °C and measured with an emission coefficient of 0.98.

**ELECTRICAL CHARACTERISTICS**

Parameter	09Sil	09Std	09Micro	Units
Supply Voltage	4 - 16		2.2 - 3.3	V
Supply current(typ)	1 - 4			mA
Emission coefficient	0.98			
Field of view	14	90	120	°
Start-up time	5			s
Stabilization time	3			min
Object temperature	0 - 300	0 - 50		°C
Accuracy *)	4.5	2		°C
Accuracy ( 16°C<Tobj<36°C) *)		0.55	0.55	°C
T ambient	0 - 85			°C

\*) Accuracy counts for Tambient between 10 and 40 °C

# INFRARED SENSOR MODULE SMTIRM0009

last update  
October 19, 2016

reference  
smtirmodules manual n

page  
2/6

for more info:  
[sales@smartec-sensors.com](mailto:sales@smartec-sensors.com)



# INFRARED SENSOR MODULE SMTIRMOD09

## Encapsulation, mechanical outlines

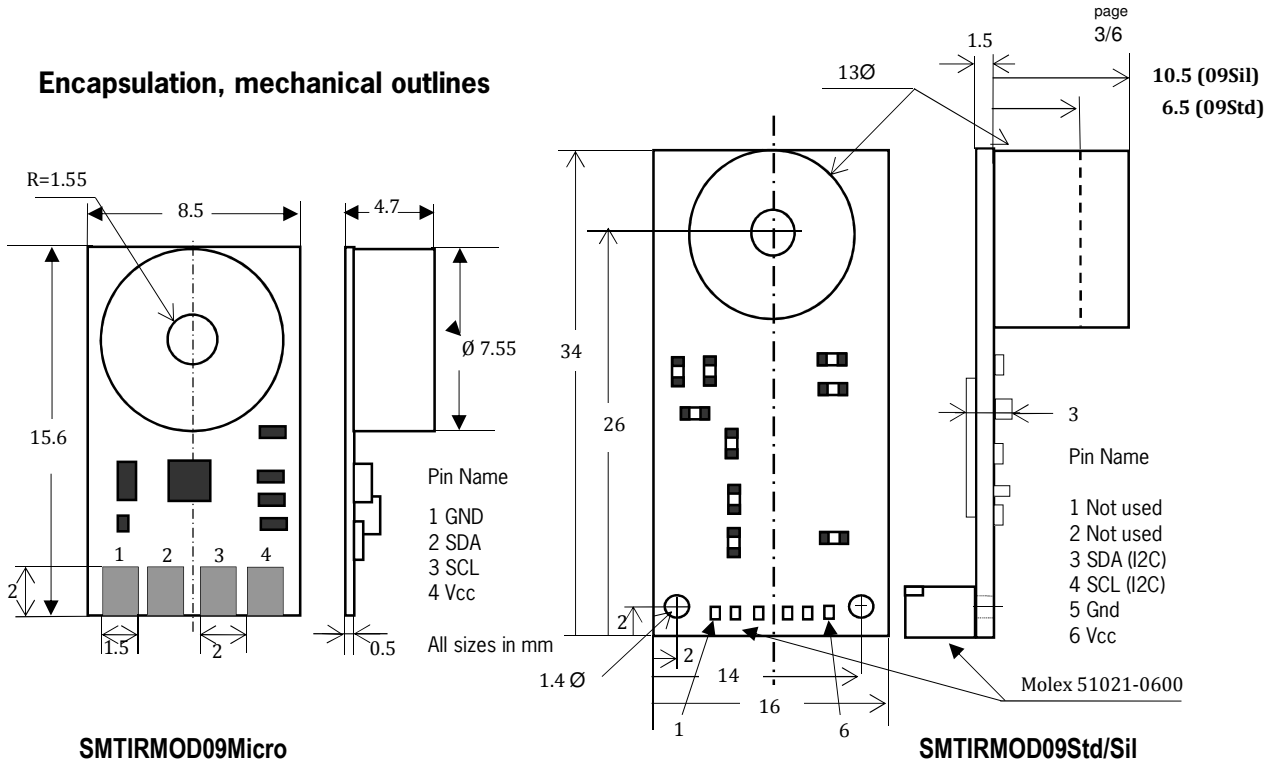

(molex 51021 0600 = Farnell 1012261 = digikey WM1724-ND)

## I<sup>2</sup>C interface

All the devices are working in the slave mode of a two wire I<sup>2</sup>C interface. The address length is always 7 bits. The standard address is 0x2A.

Below a table with the specifications of the I<sup>2</sup>C hardware

### I<sup>2</sup>C interface parameters

Parameter	Min	Typ	Max	Unit
Baudrate	10		50	kB/s
Standard address		2A		hex
Address length		7		Bits
Input high level	2		3.6	V
Input low level			1	V
Output high level	2.5			V
Output low level			1	V

### Start/stop

Start setup time	4.7			µs
Start hold time	4.0			µs
Stop setup time	4.0			µs

### Data

Parameter	Min	Max	Unit
Clock high time	4.0	50	µs
Clock low time	4.7		µs
SDA/SCL rise time		1	µs
SDA/SCL fall time		0.3	µs
Data input hold time	0.3		µs
Data setup time	0.25		µs
Bus free time	47		µs



## INFRARED SENSOR MODULE SMTIRMOD09

The timing diagram of the data is given in the table below and can be considered as a standard for the I<sup>2</sup>C communication.

### MEASUREMENT OF TEMPERATURES

The software installed in the modules send to the interface both the object temperature as well as the ambient temperature (= module temperature). Both the values are given in hundreds of a degree °C.

Command	Description	Bytes
<b>0xB6</b>	<b>read object temperature in 0.01 °C resolution</b>	<b>2</b>
<b>0xB5</b>	<b>read ambient temperature in 0.01 °C resolution</b>	<b>2</b>

### EXAMPLE

For reading an object temperature a 0XB6 is send. The device replies with e.g. 0x0E and 0xAA;

$$T_{obj} = (256 * 0E + AA) / 100 = (256 * 14 + 170) / 100 = 37.54 \text{ °C}$$

For convenience of the user and over and underflow indication is installed. Please find below the table how the device replies in in case of under- overflow.

command	response	Description
<b>0xB6</b>	<b>0xFFFF0</b>	<b>Object temp &gt; Tobj Max</b>
<b>0xB6</b>	<b>0xFFFF1</b>	<b>Object temp &lt; 0 °C</b>
<b>0xB5</b>	<b>0xFFFF</b>	<b>Ambient temp &gt; 85 °C</b>
<b>0xB5</b>	<b>0xF000</b>	<b>Ambient temp &lt;0 °C</b>

### SMTIRMOD communication protocol

The communication between the host and the SMTIRMOD must strictly follow the rules as defined by the I<sup>2</sup>C-bus management. The host must send START condition, SMTIRMOD address (7 bits) and R/W = 0 (Write). SMTIRMOD will place ACK (Acknowledge) if the device is present and the address is recognized. If ACK is present than the host should send the command byte (0xB5 or 0xB6) and the device will place ACK signal again. After that the host should send another START condition, followed by the SMTIRMOD address (7 bits) and R/W = 1 (Read). SMTIRMOD will acknowledge it and reply with 2 bytes – temperature data. The host should acknowledge the first byte and not-acknowledge the second byte. After that the host should send a STOP condition. In case any ACK byte is missing the host should immediately send a STOP condition. The protocols for SMTIRMOD read operations are illustrated on the figures below.



## INFRARED SENSOR MODULE SMTIRMOD09

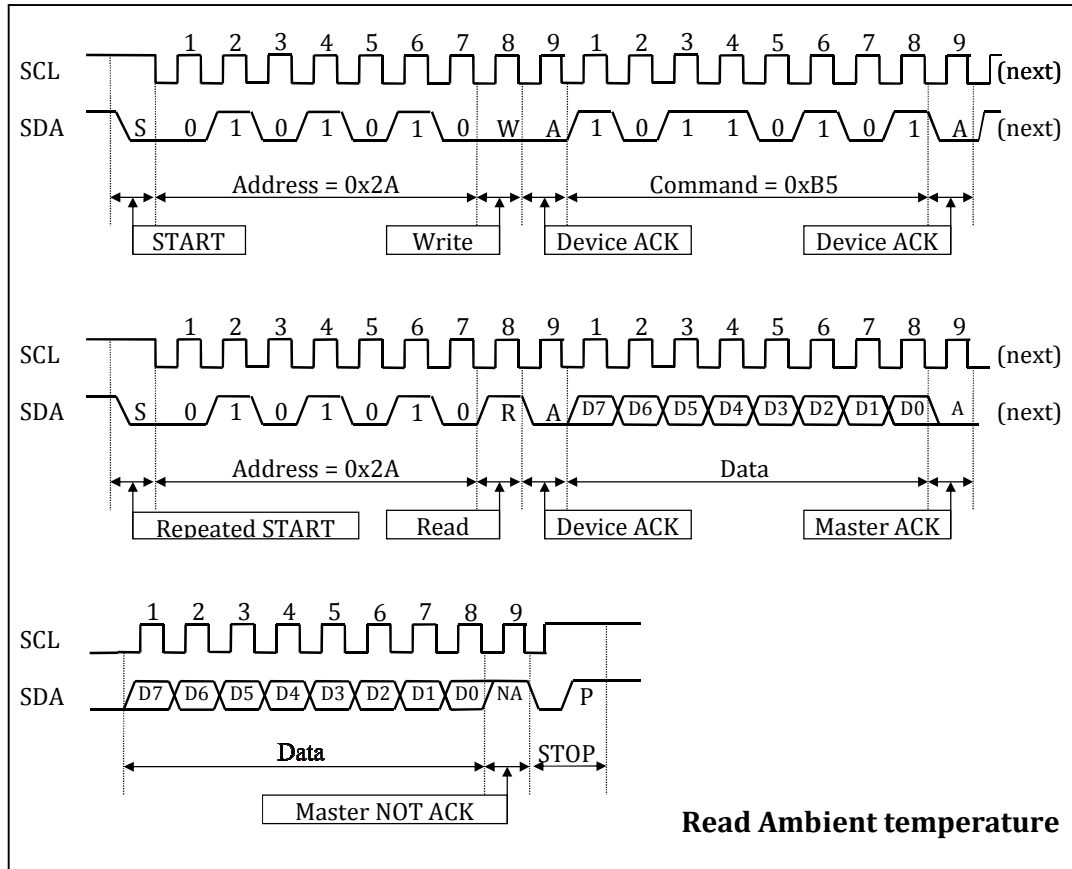

- Before a communication, the I<sup>2</sup>C-bus must be free or not busy. It means that the SCL and SDA lines must both be released by all devices on the bus, and they become HIGH by the bus pull-up resistors.
- The host must provide SCL clock pulses necessary for the communication. Data is transferred in a sequence of 9 SCL clock pulses for every 8-bit data byte followed by 1-bit status of the acknowledgement.
- During data transfer, except the START and STOP signals, the SDA signal must be stable while the SCL signal is HIGH. It means that the SDA signal can be changed only during the LOW duration of the SCL line.
- S: START signal, initiated by the host to start a communication, the SDA goes from HIGH to LOW while the SCL is HIGH.
- P: STOP signal, generated by the host to stop a communication, the SDA goes from LOW to HIGH while the SCL is HIGH. The bus becomes free thereafter.
- W: write bit, when the write/read bit = LOW in a write command.
- R: read bit, when the write/read bit = HIGH in a read command.
- A: device acknowledge bit, returned by the SMTIRMOD. It is LOW if the device works properly and HIGH if not. The host must release the SDA line during this period in order to give the device the control on the SDA line.
- A': master acknowledge bit, not returned by the device, but set by the master or host in reading 2-byte data. During this clock period, the host must set the SDA line to LOW in order to notify the device that the first byte has been read for the device to provide the second byte onto the bus.



## INFRARED SENSOR MODULE SMTIRMOD09

- NA: Not Acknowledge bit. During this clock period, both the device and host release the SDA line at the end of a data transfer, the host is then enabled to generate the STOP signal.
- In a write protocol, data is sent from the host to the device and the host controls the SDA line, except during the clock period when the device sends the device acknowledgement signal to the bus.
- In a read protocol, data is sent to the bus by the device and the host must release the SDA line during the time that the device is providing data onto the bus and controlling the SDA line, except during the clock period when the master sends the master acknowledgement signal to the bus.

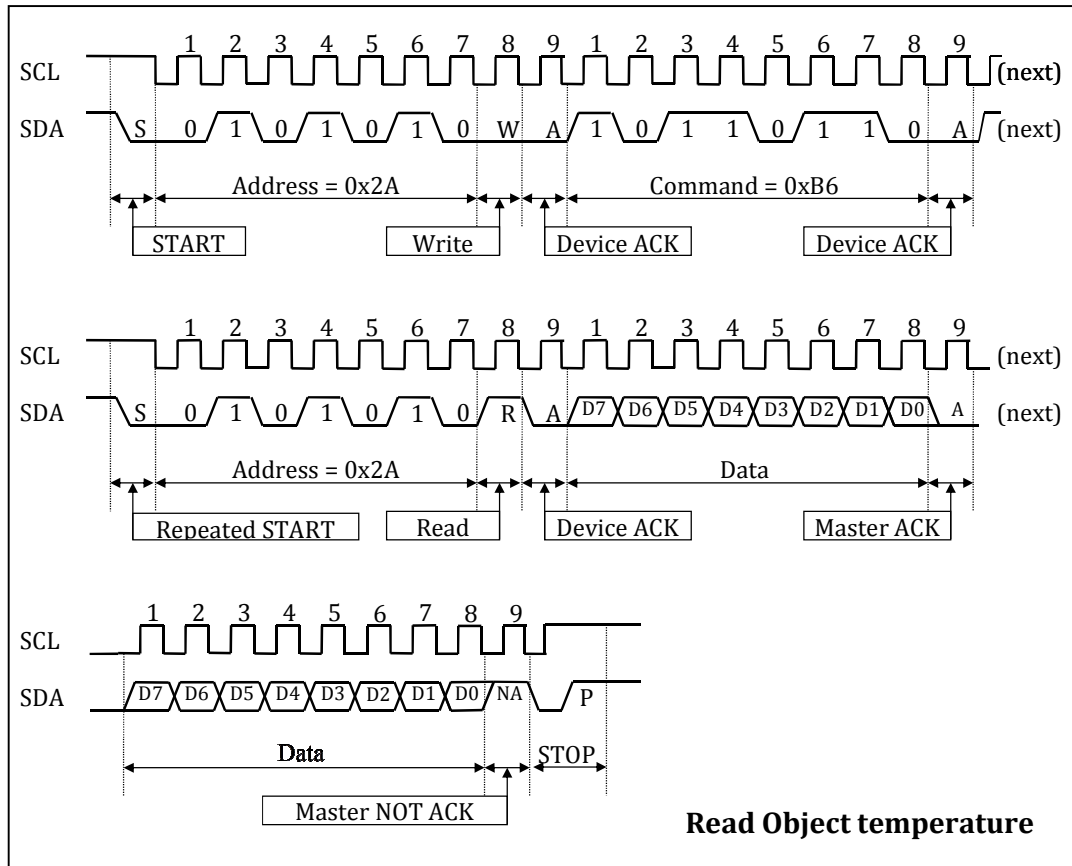

### Ordering code:

**SMTIRMOD09SiI** Infrared module field of view 14 °C, Tobj < 300 °C

**SMTIRMOD09Std** Infrared module field of view 70 °C, Tobj < 50 °C

**SMTIRMOD09Micro** Infrared module field of view 120 °C, Tobj < 50 °C

[sales@smartec-sensors.com](mailto:sales@smartec-sensors.com)

for more info:

[sales@smartec-sensors.com](mailto:sales@smartec-sensors.com)

