

The Smart two temperature sensor board has also an input for Smartec I<sup>2</sup>C sensors.

For the temperature sensors the measuring range is -45°C up to +130 °C using Smartec temperature sensors and sends the temperature and I<sup>2</sup>C information as a standard ASCII string. The system is based on a Microchip's PIC12F629 microcontroller and uses an FTDI chip interface to connect via USB port to any type of laptop/PC. Via the USB-connection the board is powered. Due to a variety of sensors there are two boards available, one with I<sup>2</sup>C on 3 Volts and one with I<sup>2</sup>C on 5 Volts power supply.

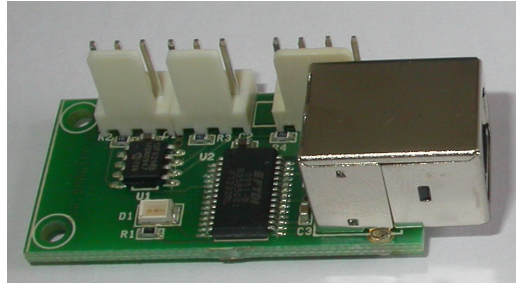

Up to 2 SMT160-30 sensors can be connected simultaneously; the software will test the inputs automatically on power up after which it will process only the ones with sensors connected. The measurement will start automatically after connecting the board to a USB port and after configuration of the corresponding virtual COM port. The board will be powered via the computer.

The measurement results of different sensors are separated in the output string by a 'SPACE' (\$20). The consecutive measurements are separated by LF, CR (\$0D, \$0A) commands.

Each measured value is sent in 5 or 6 bytes. For instance 20.15°C is sent as '2' then '0' then '.' and '1' and finally '5'. In case the temperature is above 100 °C an extra byte is sent '1' and in case the temperature is negative a minus is sent before. In case no temperature sensor is connected an "\*" will be generated. For the I<sup>2</sup>C readout we point to the module datasheet.

One measurement cycle and calculation takes approximately 500 ms, but it depends on the temperature and number of connected sensors.

Every program, capable of receiving standard ASCII strings, for example Hyper Terminal of Windows XP/vista/7, can visualize the results.

The communication of the virtual COM port has to be configured in the following way:

- Baud Rate: 9.600 Kb
- Data bits: 8
- Stop bit: 1
- Parity check: None
- Flow control: None
- 

The measurement will start immediately after the board is connected to the serial port and the controlling program is started. At the same time the LED on the board will light up. If this does not happen, please check the serial port connection and configuration.

# SMTAS02I2C

## SMTAS02IIC Schematic

5V version

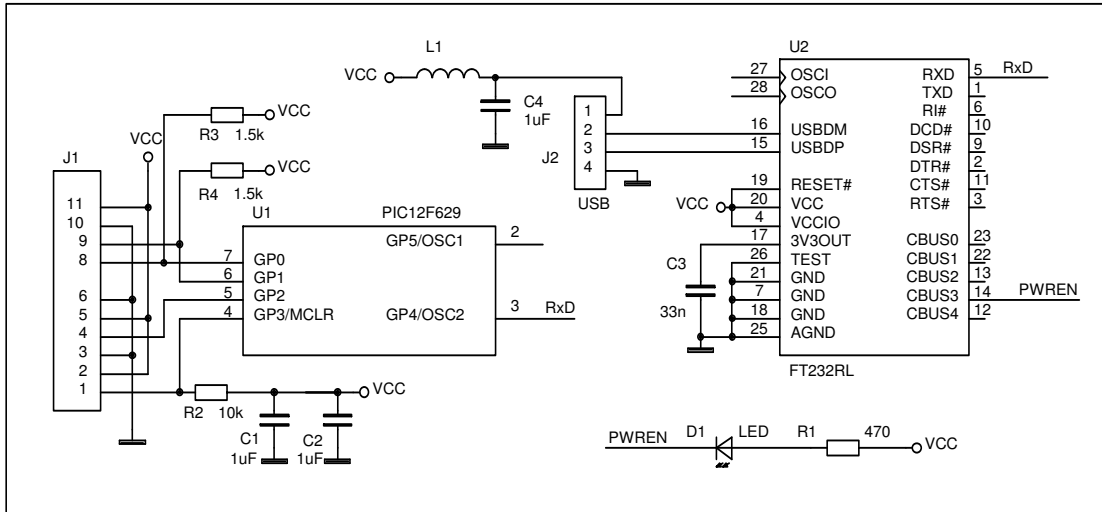

3V version

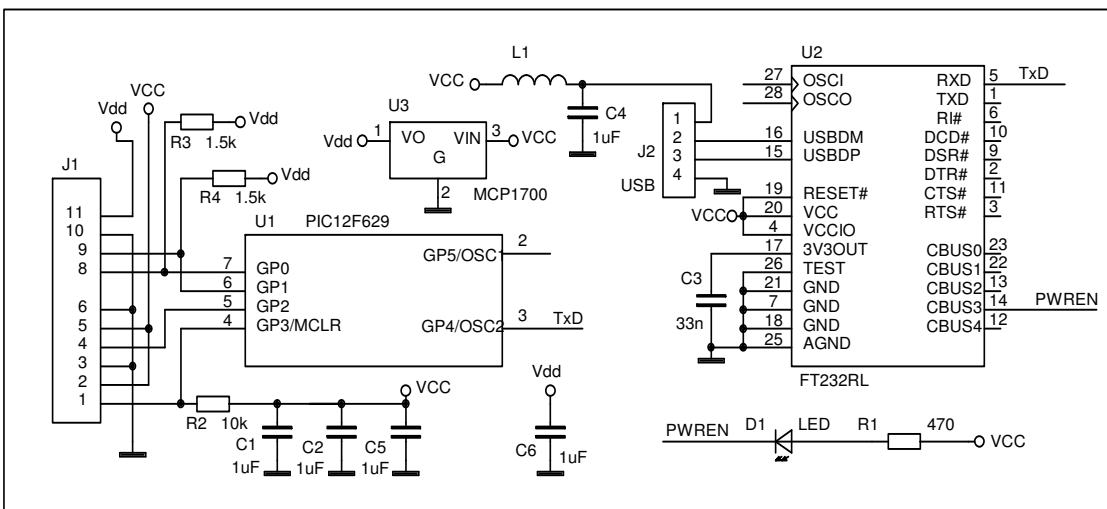

Pinout of sensor connector J1 (5 V version):

- 1 Output sensor 1
- 2 Vcc sensor1
- 3 Gnd sensor 1
- 4 Output sensor 2
- 5 Vcc sensor 2
- 6 Gnd sensor 2



## SMTAS02I2C

8*)	SDA (I <sup>2</sup> C)
9	SCL (I <sup>2</sup> C)
10	Gnd (I <sup>2</sup> C)
11	Vcc (I <sup>2</sup> C)

Pinout of sensor connector J1( 3V version):

1	Output sensor 1
2	Vcc sensor1
3	Gnd sensor 1
4	Output sensor 2
5	Vcc sensor 2
6	Gnd sensor 2

8*)	Gnd (I <sup>2</sup> C)
9	SDA (I <sup>2</sup> C)
10	SCL (I <sup>2</sup> C)
11	Vcc (I <sup>2</sup> C)

\*) be aware both the 5V. and 3V. versions have different pin out on I<sup>2</sup>C due to connection optimizing for SMTIRMOD09 boards



Program Flow chart

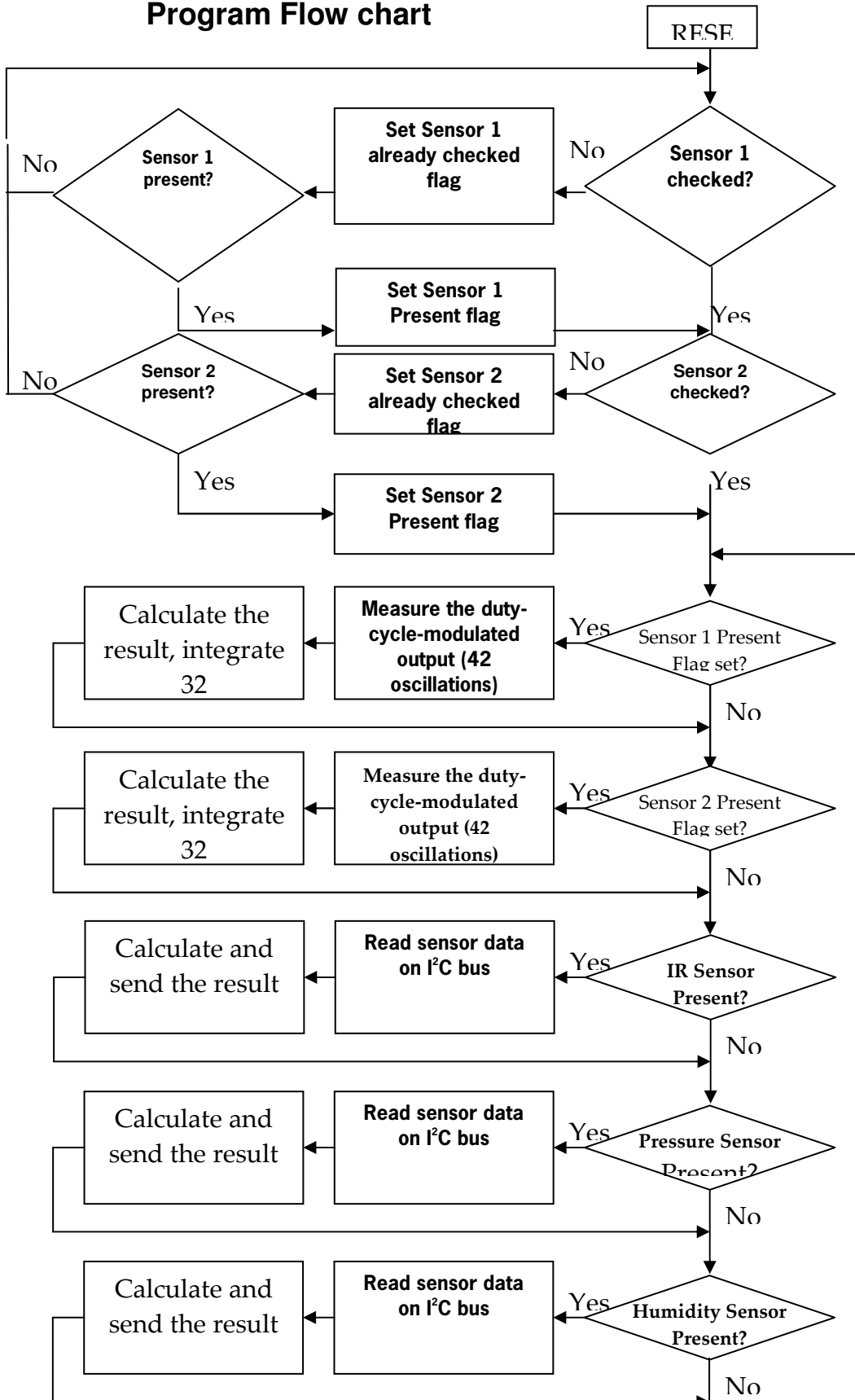

### SMT160-30 sensor reading

The measurement routine for SMT160-30 is based on a free running 16-bit timer TMR1. The counting frequency is 1 MHz. The flowchart of the measurement routine is shown on the figure:

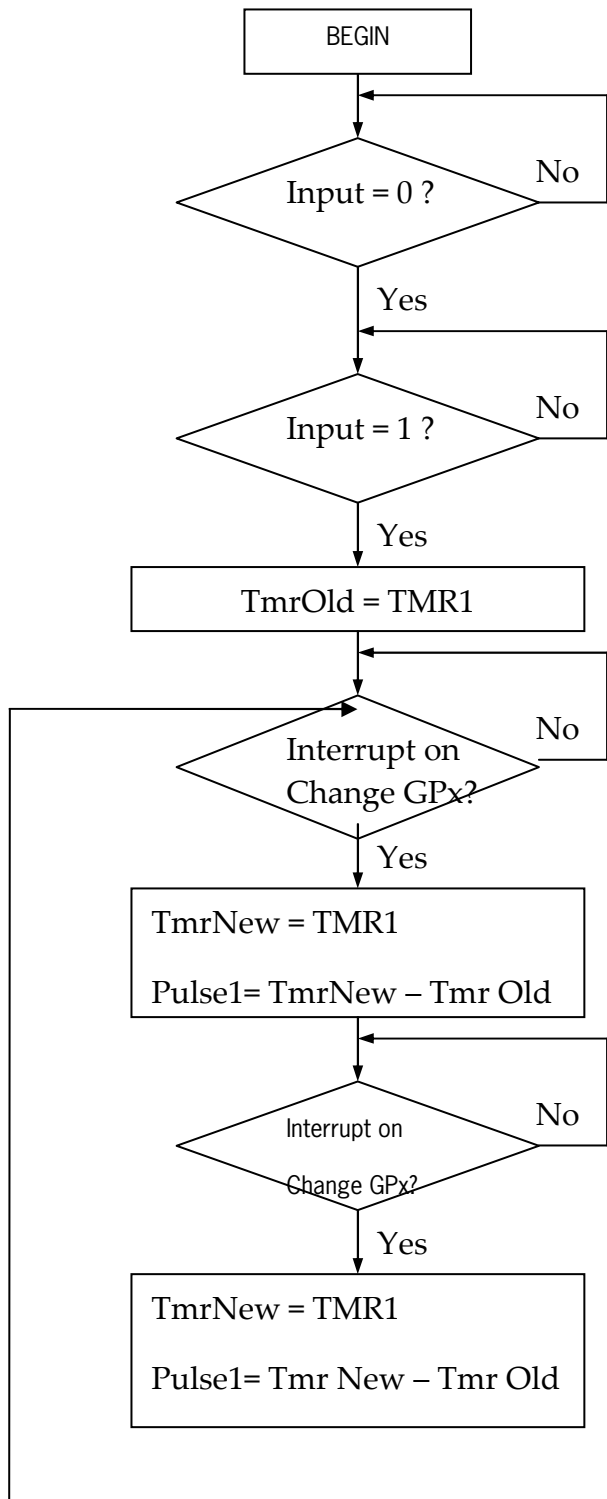

The result is calculated according to the formula:

$$\text{D.C.} = \text{Pulse1} / (\text{Pulse0} + \text{Pulse1})$$

$$\text{Temperature} = (\text{D.C.} - 0.3200) / 0.0047$$

---

## I<sup>2</sup>C sensor reading

### General conventions

- Before a communication can start, the I<sup>2</sup>C -bus must be free or not busy. It means that the SCL and SDA lines must both be released by all devices on the bus, and they become HIGH by the bus pull-up resistors.
- The host must provide SCL clock pulses necessary for the communication. Data is transferred in a sequence of 9 SCL clock pulses for every 8-bit data byte followed by 1-bit status of the acknowledgement.
- During data transfer, except for the START and STOP signals, the SDA signal must be stable whilst the SCL signal is HIGH. It means that the SDA signal can be changed only during the LOW duration of the SCL line.
- S: START signal, initiated by the host to start a communication, the SDA goes from HIGH to LOW while the SCL is HIGH.
- P: STOP signal, generated by the host to stop a communication, the SDA goes from LOW to HIGH while the SCL is HIGH. The bus becomes free thereafter.
- W: write bit, when the write/read bit = LOW in a write command.
- R: read bit, when the write/read bit = HIGH in a read command.
- A: device acknowledge bit, returned by the SMTIRMOD. It is LOW if the device works properly and HIGH if not. The host must release the SDA line during this period in order to give the device the control on the SDA line.
- A': master acknowledge bit, not returned by the device, but set by the master or host in reading 2-byte data. During this clock period, the host must set the SDA line to LOW in order to notify the device that the first byte has been read for the device to provide the second byte onto the bus.
- NA: Not Acknowledge bit. During this clock period, both the device and host release the SDA line at the end of a data transfer, the host is then enabled to generate the STOP signal.
- In a write protocol, data are sent from the host to the device and the host controls the SDA line, except during the clock period when the device sends the device acknowledgement signal to the bus.
- In a read protocol, data are sent to the bus by the device and the host must release the SDA line during the time that the device is providing data onto the bus and controlling the SDA line, except during the clock period when the master sends the master acknowledgement signal to the bus.



## The SMTIRMOD09 communication protocol (3-5 V. I<sup>2</sup>C)

The communication between the host and the SMTIRMOD09 must strictly follow the rules as defined by the I<sup>2</sup>C-bus management. The host must send a START condition, SMTIRMOD09 address (7 bits) and R/W = 0 (Write). SMTIRMOD09 will place ACK (Acknowledge) if the device is present and the address is recognized. If ACK is present then the host should send the command byte (0xB5 or 0xB6) and the device will send ACK signal again. After that the host should send another START condition, followed by the SMTIRMOD09 address (7 bits) and R/W = 1 (Read). SMTIRMOD09 will acknowledge it and reply with 2 bytes – temperature data. The host should acknowledge the first byte and not-acknowledge the second byte. After that the host should send a STOP condition. In case any ACK byte is missing the host should immediately send a STOP condition. The protocols for SMTIRMOD09 read operations are illustrated on the figures below.

### Read Ambient temperature of SMTIRMOD09

Start	54hex(WriteCmd)	ACK	B5hex (Cmd)	ACK				
Start	55hex(ReadCmd)	ACK	Data0	ACK	Data1	NACK	Stop	

(Master controls the SDA line

Slave controls the SDA line)

### Read Object temperature of SMTIRMOD09

Start	54hex(WriteCmd)	ACK	B6hex (Cmd)	ACK				
Start	55hex(ReadCmd)	ACK	Data0	ACK	Data1	NACK	Stop	

(Master controls the SDA line

Slave controls the SDA line)



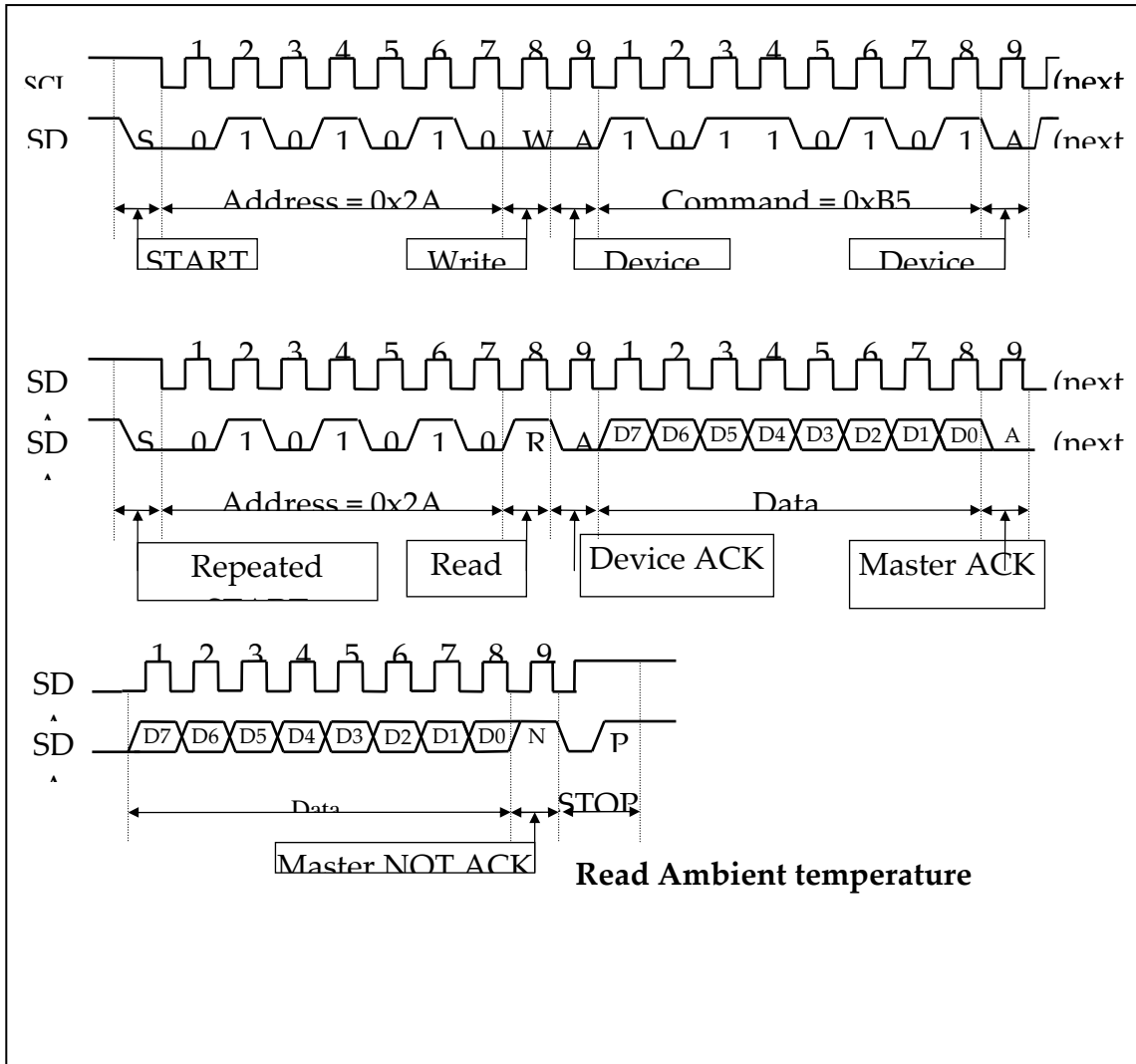



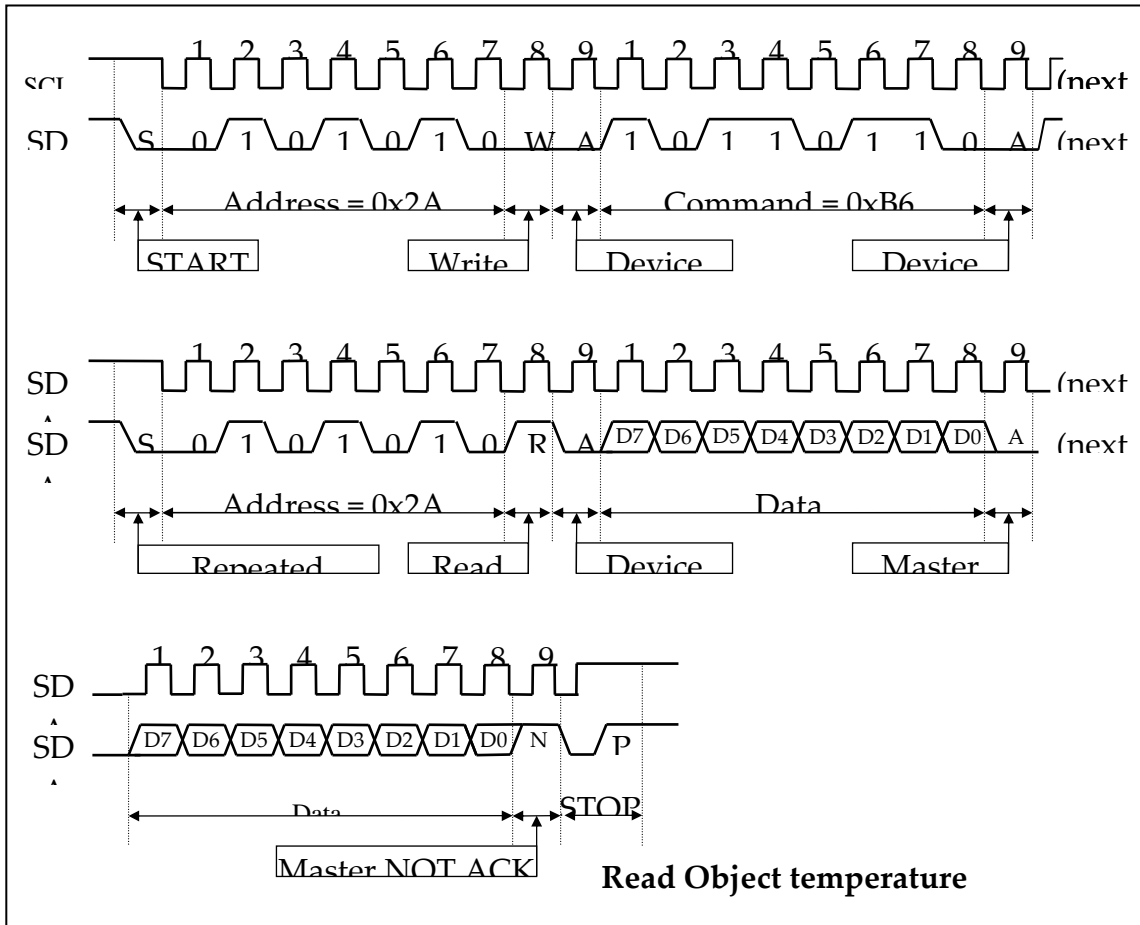

## SMTAS02I2C

### The SMTH08I Humidity & Temperature Sensor communication protocol

The SMTH08I is a sophisticated combination of a Temperature and a Humidity sensor. Its available is a small 8 pins SOP 5 x 6.5 mm housing. The power supply voltage is 3 V so suitable for all kind of battery operated equipment. For further information about this sensor please read the SMTH08I specification sheet. Below only the communication with the SMTAS02I2C is depicted.

#### Humidity conversion procedure

<b>Start</b>	<b>83hex(HumiCmd)</b>	<i>NACK</i>	<b>Stop</b>				
Wait 220 ms							
<b>Start</b>	<b>80hex(WriteCmd)</b>	<i>ACK</i>	<b>10hex (Addr)</b>	<i>ACK</i>			
<b>Start</b>	<b>81hex(ReadCmd)</b>	<i>ACK</i>	<i>Data0(R16)</i>	<b>ACK</b>	<i>Data1(R17)</i>	<b>NACK</b>	<b>Stop</b>

(Master controls the SDA line

Slave controls the SDA line)

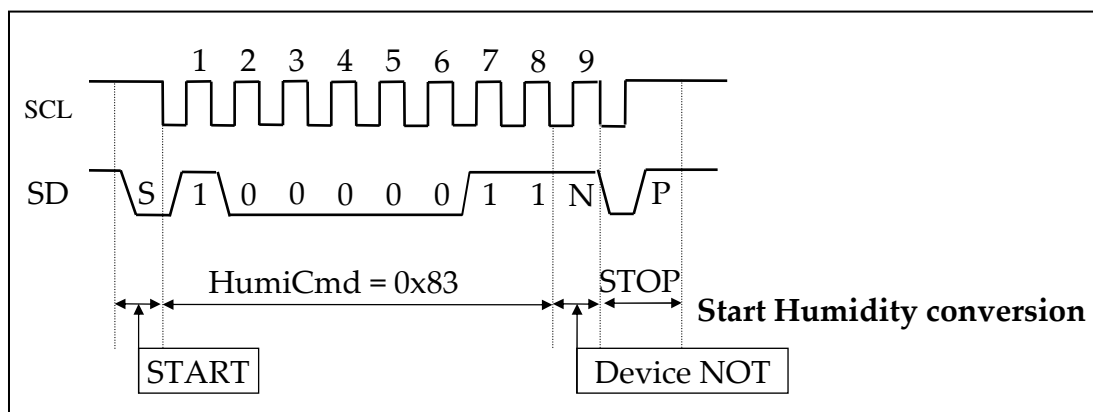

# SMTAS02I2C

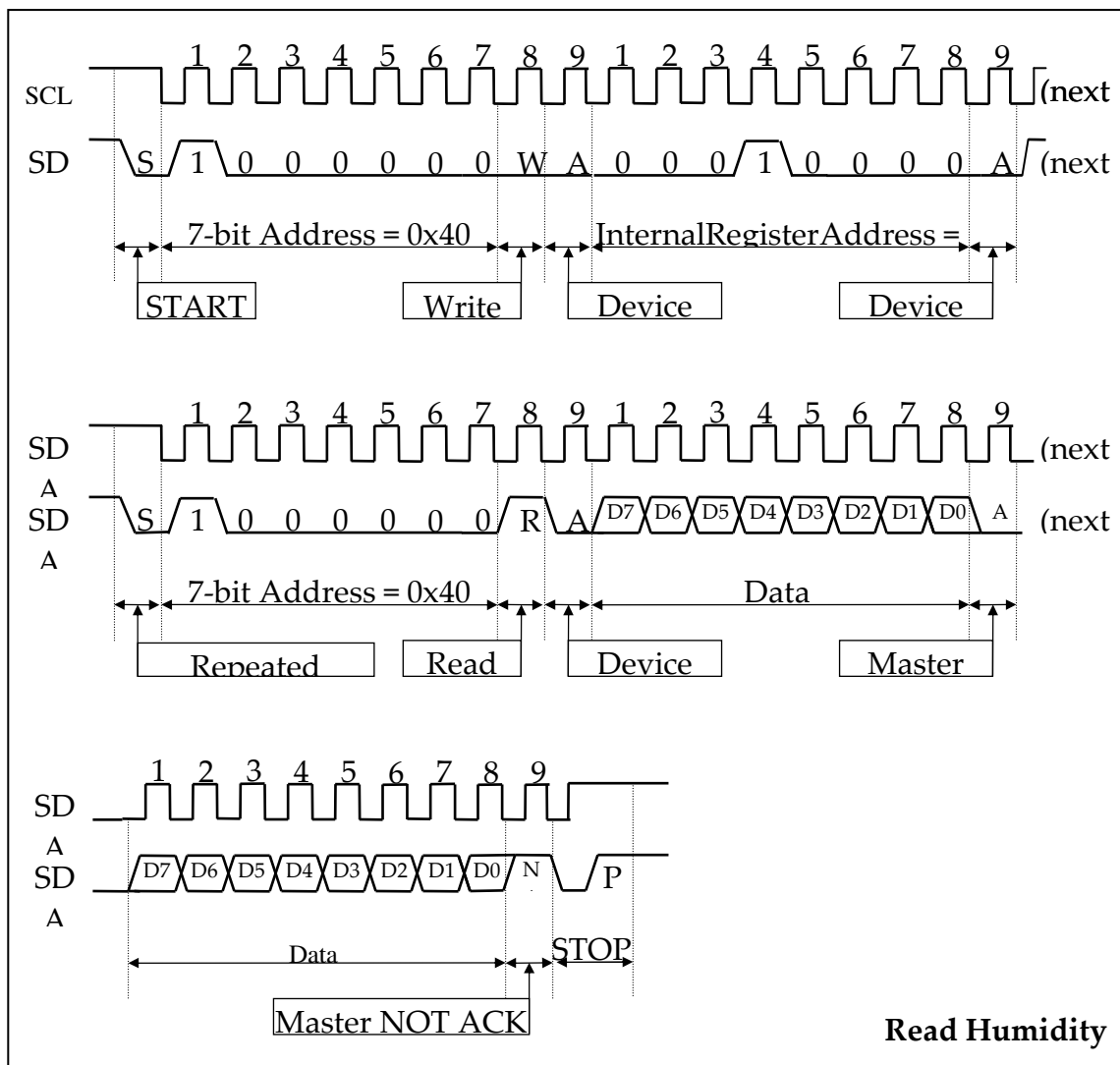

Read Humidity

## Temperature conversion procedure

Start	82hex(HumiCmd)	NACK	Stop
Wait 110 ms			
Start	80hex(WriteCmd)	ACK	12hex (Addr) ACK
Start	81hex(ReadCmd)	ACK	Data0(R17) ACK Data1(R18) NACK Stop

(Master controls the SDA line)

Slave controls the SDA line)



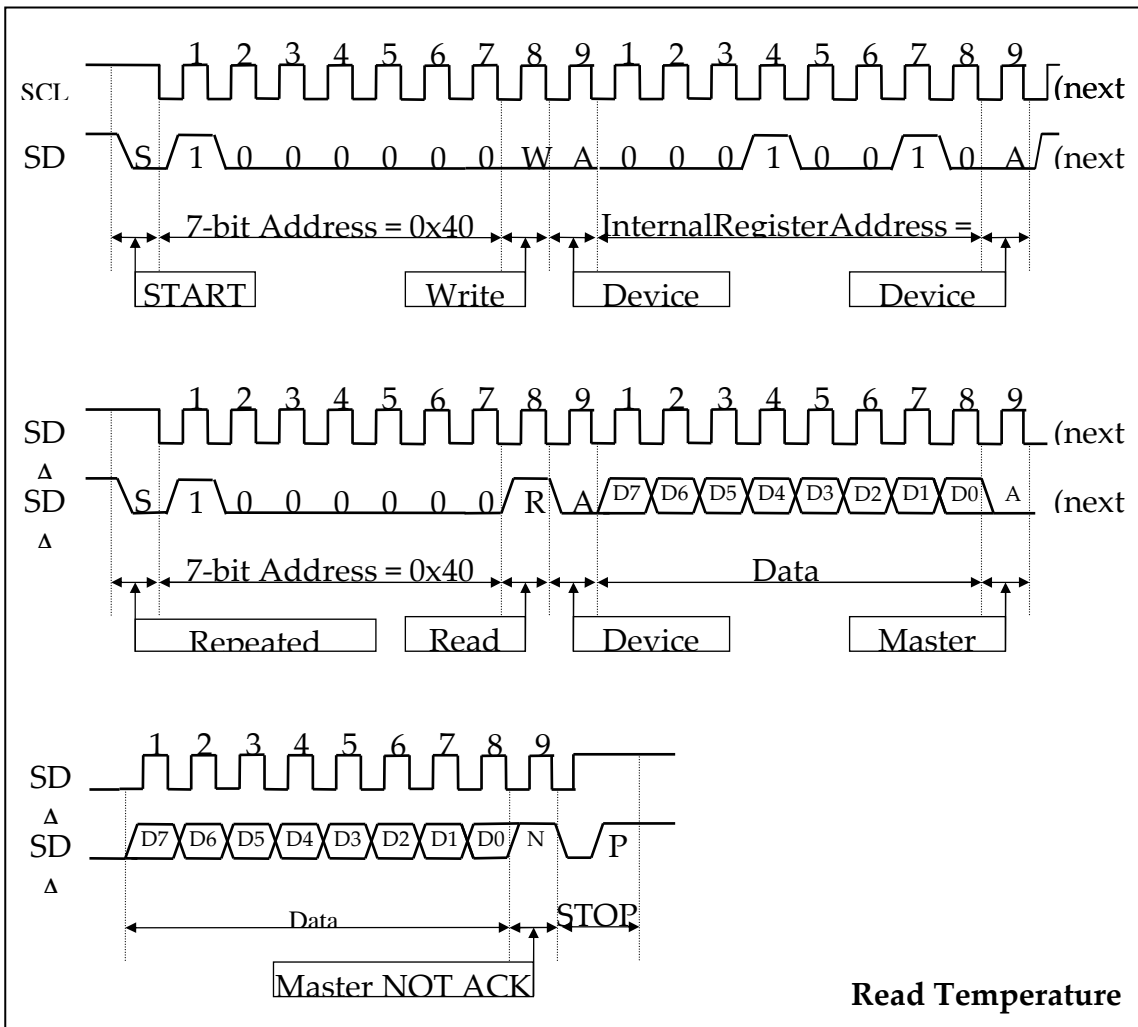
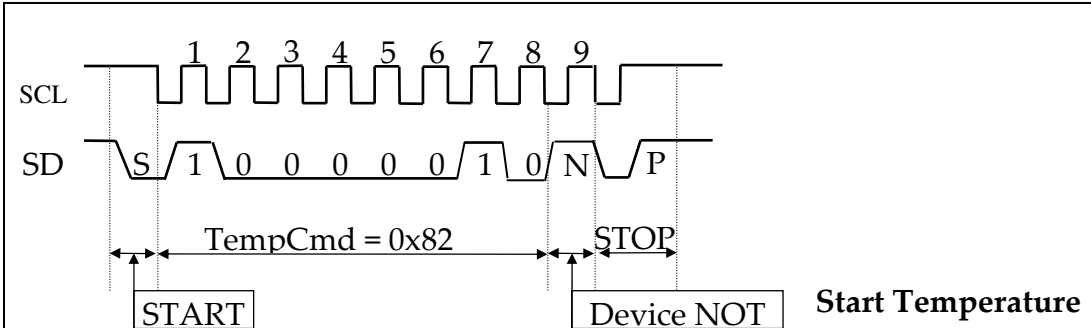

## SMTAS02I2C

Humidity & Temperature conversion procedure

<b>Start</b>	<b>83hex(HumiCmd)</b>	<i>NACK</i>	<b>Stop</b>	<b>Start</b>	<b>83hex(HumiCmd)</b>	<i>NACK</i>	<b>Stop</b>
<b>Wait 330 ms</b>							
<b>Start</b>	<b>80hex(WriteCmd)</b>	<i>ACK</i>	<b>10hex (Addr)</b>	<i>ACK</i>			
<b>Start</b>	<b>81hex(ReadCmd)</b>	<i>ACK</i>	<i>Data0(R16)</i>	<b>ACK</b>	<i>Data1(R17)</i>	<b>ACK</b>	
<i>Data2(R18)</i>	<b>ACK</b>	<i>Data1(R19)</i>	<b>NACK</b>	<b>Stop</b>			

**(Master controls the SDA line**

*Slave controls the SDA line)*

## The Pressure Sensor communication protocol (5V. I<sup>2</sup>C) For SPDxxxYlhyb

The SPDxxxYlhyb is a sophisticated pressure sensor with I<sup>2</sup>C output. For ease of doing experiments with the sensor it is also possible to connect these I<sup>2</sup>C sensors to the SMTAS02I2C acquisition board. For further information about this sensor please read the corresponding specification sheet. Below only the communication with the SMTAS02I2C is depicted.

Pressure sensor data reading

<b>Start</b>	<b>F1hex(ReadCmd)</b>	<i>ACK</i>	<i>Data0</i>	<b>ACK</b>	<i>Data1</i>	<b>NACK</b>	<b>Stop</b>
--------------	-----------------------	------------	--------------	------------	--------------	-------------	-------------

**(Master controls the SDA line**

*Slave controls the SDA line)*



## SMTAS02I2C

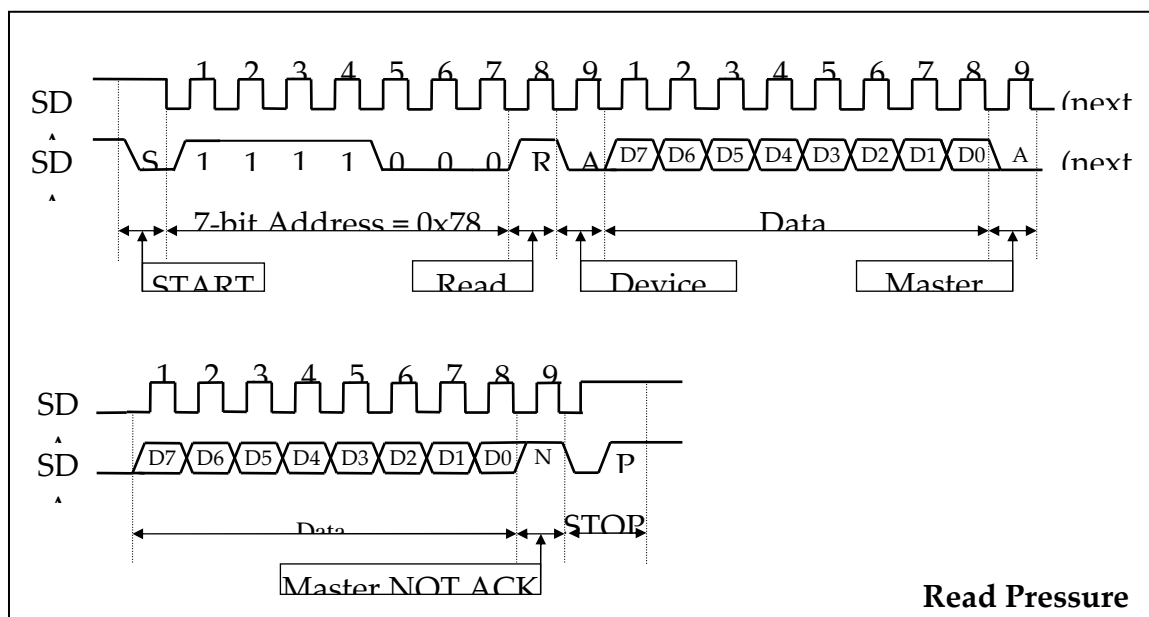

## Finally

This small PC-board is only developed as a demonstrator to show the ease of interfacing temperature sensors to micros. For the specifications of the Smartec temperature sensor please refer to the specification sheet. To make recalibration of the Infrared module for emission factors easy it is possible to make a low cost set up to measure the radiation temperature and the object temperature by means of a smartec temperature sensor. Software will be available in our Supportshop to write all kind of output figures to XLS like files

## Ordering code

**SMTAS02IIC3** Smartec Temperature Acquisition board for 2 SMT sensor and a 3 V. I<sup>2</sup>C connection.

**SMTAS02IIC5** Smartec Temperature Acquisition board for 2 SMT sensor and a 5 V. I<sup>2</sup>C connection.

## Connectors:

4-way for I<sup>2</sup>C Molex 22-01-1043, Farnell 143094, CviLux CI51 04 S 000R

3-way for SMT sensor Molex 22-01-1033, Farnell 143093, CviLux CI51 03 S 000R

Crimp inserts Molex08-50-0032, Farnell 9731474, CviLux CI51 T03 1 B E 0

